

SAW Filter

VF438901M

IF Filter for Video Applications

33.90MHz and 38.90 MHz



Features

- Standard: B/G, D/K, I, L/L'
- TV IF filter with Nyquist slope at 33.90 MHz and 38.90 MHz
- Constant group delay

Package Dimension

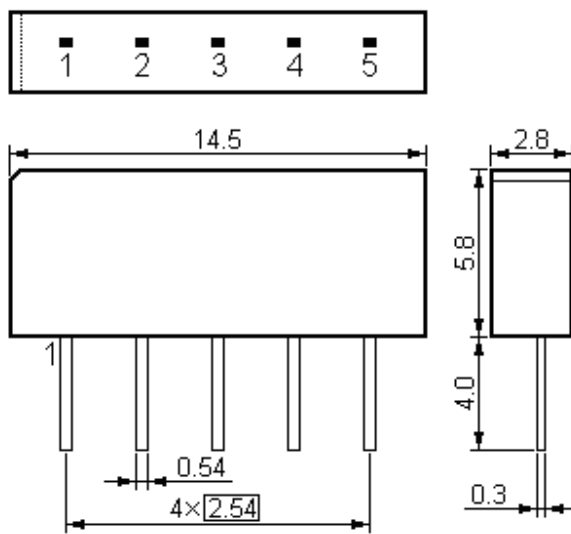

Pin Configuration

- 1 Input
- 2 Input - ground
- 3 Chip carrier - ground
- 4 Output
- 5 Output

Plastic Package **SIP5D**

Unit: mm

Marking

VTF
438901M

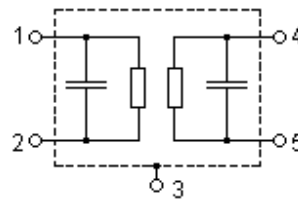

Performance

Maximum Ratings

Rating		Value	Unit
Operable Temperature Range	T_A	-25 to +65	
Storage Temperature Range	T_{stg}	-40 to +85	
DC Voltage (between any terminals)	V_{DC}	12	V
AC Voltage (between any terminals)	V_{PP}	10	V

Electronic Characteristics

Reference temperature:	$T_A = 25\text{ °C}$
Terminating source impedance:	$Z_S = 50\ \Omega$
Terminating load impedance:	$Z_L = 2\text{ k}\Omega \parallel 3\text{ pF}$

Item		min.	typ.	max.	Unit
Insertion attenuation	IL				
Reference level for the following data	37.40 MHz	12.0	13.5	15.0	dB
Relative attenuation	α_{rel}				
Picture carrier	38.90 MHz	3.5	4.5	5.5	dB
	33.90 MHz	5.8	7.0	8.2	dB
Color carrier	34.47 MHz	—	1.3	—	dB
Sound carrier	33.40 MHz	20.0	25.0	—	dB
	32.90 MHz	—	43.0	—	dB
	32.40 MHz	—	58.0	—	dB
Adjacent picture carrier	30.90 MHz	48.0	65.0	—	dB
	31.90 MHz	42.0	52.0	—	dB
	40.15 MHz	30.0	34.0	—	dB
Adjacent sound carrier	40.40 MHz	35.0	43.0	—	dB
	41.40 MHz	45.0	60.0	—	dB
	40.90 MHz	40.0	52.0	—	dB
Lower sidelobe	25.00 ... 31.90 MHz	35.0	42.0	—	dB
Upper sidelobe	40.40 ... 45.00 MHz	32.0	40.0	—	dB
Reflected wave signal suppression					
1.2 μ s ... 6.0 μ s after main pulse (test pulse 250 ns, carrier frequency 37.40 MHz)		42.0	50.0	—	dB
Feedthrough signal suppression					
1.2 μ s ... 1.1 μ s before main pulse (test pulse 250 ns, carrier frequency 37.40 MHz)		50.0	56.0	—	dB
Group delay ripple (p-p)	$\Delta\tau$	—	50	—	ns
Temperature coefficient of frequency	TC_f	—	-72	—	ppm/K

Frequency Response

