

MCF

APPLICATIONS

Monolithic Crystal Filter
Leaded / jacket available for SMD

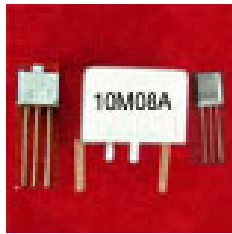

- ▶ Pager
- ▶ Wireless phone
- ▶ Communication system
- ▶ High reliability and precision

ELECTRICAL SPECIFICATIONS

Model	Nominal Frequency	Channel Spacing	No. of pole	Pass band width		Stop band width		Ripple	Insertion loss	Terminal impedance	Package
	MHz	KHz		dB	KHz	dB	KHz	dB	dB	K Ω / pF	

>>> 10.7MHz Family / Fundamental mode <<<

10M08A	10.700	12.5	2	3	± 3.75	20	± 18	0.5	2.0	1.8 // 5	HC-49/T
10M12A	10.700	20.0	2	3	± 6.00	18	± 20	0.5	2.0	3.0 // 3	
10M15A	10.700	25.0	2	3	± 7.50	18	± 25	0.5	3.0	3.0 // 2	
10M30A	10.700	50.0	2	3	± 15.0	18	± 50	0.5	2.0	5.0 // 1	
10M08B	10.700	12.5	4	3	± 3.75	40	± 14	1.0	2.5	1.8 // 4 // 12	HC-49/T x 2
10M12B	10.700	20.0	4	3	± 6.00	40	± 20	1.0	2.5	2.8 // 1.5 // 7	
10M15B	10.700	25.0	4	3	± 7.50	40	± 25	1.0	2.5	3.0 // 1 // 5	
10M30B	10.700	50.0	4	3	± 15.0	40	± 50	1.0	2.5	5.5 // -1 // 0	
10M08C	10.700	12.5	6	3	± 3.75	85	± 12.5	2.0	3.5	1.6 // 4	C-1
10M12C	10.700	20.0	6	3	± 6.00	65	± 20	2.0	3.0	3.0 // 1.5	
10M15C	10.700	25.0	6	3	± 7.50	65	± 25	2.0	2.5	3.0 // 2	
10M30C	10.700	50.0	6	6	± 15.0	60	± 48	2.0	2.5	5.5 // 1	
10M12D	10.700	20.0	8	3	± 6.00	90	± 20	2.0	3.5	3.0 // 1.5	D-1
10M15D	10.700	25.0	8	3	± 7.50	80	± 20	2.0	3.5	3.0 // 2.0	
10M30D	10.700	20.0	8	6	± 15.0	80	± 40	2.0	3.5	5.5 // 1	
10M08E	10.700	12.5	10	3	± 3.75	90	± 10.5	2.0	5.0	1.6 // 4	E-1
10M15E	10.700	25.0	10	3	± 7.50	90	± 17.5	2.0	4.0	3.0 // 2	

>>> 21.4MHz Family / Fundamental mode <<<

21M08A	21.400	12.5	2	3	± 3.75	18	± 14.0	0.5	1.5	0.85 // 6	UM-1 UM-5 UM-4
21M09A	21.400	12.5	2	3	± 4.50	14	± 12.0	0.5	1.5	0.85 // 7	
21M12A	21.400	20.0	2	3	± 6.00	15	± 20.0	0.5	1.5	1.2 // 2.5	
21M15A	21.400	25.0	2	3	± 7.50	18	± 25.0	0.5	1.5	1.5 // 3	
21M20A	21.400	25.0	2	3	± 10.0	10	± 25.0	0.5	1.5	1.8 // 1.5	
21M30A	21.400	50.0	2	3	± 15.0	15	± 45.0	0.5	1.5	3.0 // 0.5	
21P08A	21.600	12.5	2	3	± 3.75	18	± 14.0	0.5	1.5	0.85 // 5	
21P12A	21.600	20.0	2	3	± 6.00	15	± 20.0	0.5	1.5	1.2 // 2.5	
21P12A	21.600	25.0	2	3	± 7.50	18	± 25.0	0.5	1.5	1.5 // 3	
21T07A	21.700	12.5	2	3	± 3.75	18	± 14.0	0.5	1.5	0.85 // 5	
21T09A	21.700	12.5	2	3	± 4.50	14	± 12.5	0.5	1.5	1.5 // 4	
21T12A	21.700	20.0	2	3	± 6.00	15	± 20.0	0.5	1.5	1.2 // 2.5	
21T15A	21.700	25.0	2	3	± 7.50	18	± 25.0	0.5	1.5	1.5 // 3	
21T20A	21.700	25.0	2	3	± 10.0	10	± 25.0	0.5	1.5	1.8 // 1.5	
21T30A	21.700	50.0	2	3	± 15.0	15	± 45.0	0.5	1.5	3.0 // 0.5	
21M07B	21.400	12.5	4	3	± 3.75	40	± 14.0	1.0	2.0	0.85 // 5 // 16	UM-1 x 2 UM-5 x 2 UM-4 x 2
21M08B	21.400	12.5	4	3	± 4.00	40	± 16.0	1.0	2.0	1.0 // 4.5 // 13.5	
21M12B	21.400	20.0	4	3	± 6.00	40	± 20.0	1.0	2.0	1.2 // 2.5 // 10.5	
21M15B	21.400	25.0	4	3	± 7.50	40	± 25.0	1.0	2.0	1.5 // 2 // 8	
21M20B	21.400	50.0	4	3	± 15.0	40	± 50.0	1.0	2.0	3.3 // 0.5 // 3	
21P07B	21.600	12.5	4	3	± 3.75	40	± 14.0	1.0	2.0	0.85 // 5 // 16	
21P12B	21.600	20.0	4	3	± 6.00	40	± 20.0	1.0	2.0	1.2 // 2.5 // 10.5	
21P15B	21.600	25.0	4	3	± 7.50	40	± 25.0	1.0	2.0	1.5 // 2 // 8	
21T07B	21.700	12.5	4	3	± 3.75	40	± 14.0	1.0	2.0	0.85 // 5 // 16	
21T12B	21.700	20.0	4	3	± 6.00	40	± 20.0	1.0	2.0	1.2 // 2.5 // 10.5	
21M15B	21.700	25.0	4	3	± 7.50	40	± 25.0	1.0	2.0	1.5 // 2 // 8	
21M30B	21.700	50.0	4	3	± 15.0	40	± 50.0	1.0	2.0	3.3 // 0.5 // 3	
21M08C	21.400	12.5	6	3	± 3.75	65	± 12.5	2.0	3.0	0.85 // 4	D-5
21M12C	21.400	20.0	6	3	± 6.00	65	± 20.0	2.0	2.5	1.2 // 2	
21M15C	21.400	25.0	6	6	± 7.50	65	± 25.0	2.0	2.5	1.6 // 2	
21M30C	21.400	20.0	6	3	± 15.0	65	± 50.0	2.0	2.5	2.3 // 0.5	

ELECTRICAL SPECIFICATIONS											
Model	Nominal Frequency	Channel Spacing	No. of pole	Pass band width		Stop band width		Ripple	Insertion loss	Terminal impedance	Package
	MHz	KHz		dB	KHz	dB	KHz	dB	dB	K Ω / pF	

>>> 21.4MHz Family / Fundamental mode <<<

21M08D	21.400	12.5	8	3	± 3.75	90	± 12.5	2.0	4.0	0.85 // 4	D-5
21M12D	21.400	20.0	8	3	± 6.00	90	± 20.0	2.0	3.0	1.2 // 2	
21M15D	21.400	25.0	8	6	± 7.50	90	± 25.0	2.0	3.5	1.6 // 2	
21M30D	21.400	20.0	8	3	± 15.0	90	± 60.0	2.0	3.0	2.3 // 0.5	
21M08E	21.400	12.5	10	3	± 3.75	90	± 10.0	2.0	5.0	0.85 // 4	E-5
21M12E	21.400	20.0	10	3	± 6.00	90	± 16.0	2.0	4.0	1.2 // 2	
21M15E	21.400	25.0	10	6	± 7.50	90	± 18.0	2.0	4.0	1.6 // 2	

>>> 23.050, 30.875, 45.000, 55.000, 55.845MHz Family / Fundamental mode <<<

23M08A	23.050	12.5	2	3	± 3.75	16	± 12.5	0.5	1.5	1.6 // 5	UM-1 UM-5 UM-4
23M15A	23.050	25.0	2	3	± 7.50	18	± 25.0	0.5	1.5	1.5 // 3	
30M15A	30.875	25.0	2	3	± 7.50	15	± 25.0	0.5	1.5	0.8 // 6	
45M07A	45.000	12.5	2	3	± 3.50	10	± 12.5	0.5	1.5	0.51 // 5.5	
45M15A	45.000	25.0	2	3	± 7.50	14	± 25.0	0.5	1.5	0.55 // 3	
45M30A	45.000	50.0	2	3	± 15.0	10	± 50.0	0.5	1.5	0.8 // 1.5	
55M20A	55.845	40.0	2	3	± 10.0	20	± 40.0	0.5	1.5	3.6 // 0.8	UM-1 x 2 UM-5 x 2 UM-4 x 2
30M15B	30.875	25.0	4	3	± 7.50	40	± 25.0	1.0	2.5	0.8 // 4 // 12	
45M15B	45.000	25.0	4	3	± 7.50	40	± 25.0	1.0	2.5	0.65 // 3 // 10	
45M30B	45.000	50.0	4	3	± 15.0	30	± 40.0	1.0	2.5	0.8 // 1.5 // 7	
55P09B	55.000	20.0	4	3	± 4.50	30	± 25.0	1.0	2.5	0.22 // 7 // 23	

>>> 45.000MHz Family / 3'rd overtone mode <<<

T45M7.5AU1	45.000	12.5	2	3	± 3.75	10	± 12.5	1.0	2.0	2.0 // -0.4	UM-1
T45M7.5BU1	45.000	12.5	4	3	± 3.75	30	± 12.5	1.0	4.0	3.0 // -0.3 Zc : 0pF	UM-1 x 2
T45M15AU1	45.000	25.0	2	3	± 7.50	15	± 25.0	1.0	2.0	4.0 // -0.7	UM-1
T45M15BU1	45.000	25.0	4	3	± 7.50	30	± 25.0	1.0	4.0	4.0 // -0.8 Zc : -1.0pF	UM-1 x 2 (PAIR)
T45M7.5AU5	45.000	12.5	2	3	± 3.75	10	± 12.5	1.0	2.0	2.0 // -0.4	UM-5
T45M7.5BU5	45.000	12.5	4	3	± 3.75	30	± 12.5	1.0	4.0	3.0 // -0.3 Zc : 0pF	UM-5 x 2 (PAIR)
T45M15AU5	45.000	25.0	2	3	± 7.50	15	± 25.0	1.0	2.0	4.0 // -0.7	UM-5
T45M15BU5	45.000	25.0	4	3	± 7.50	30	± 25.0	1.0	4.0	4.0 // -0.8 Zc : -1.0pF	UM-5 x 2 (PAIR)

ORDERING GUIDE

1. Nominal frequency : _____ MHz
2. Pass band width : _____ dB _____ KHz min.
3. Stop band width : _____ dB _____ KHz max
4. Ripple : _____ dB max.
5. Insertion loss : _____ dB max.
6. Guaranteed attenuation : _____ KHz _____ dB min.
7. Terminating impedance : _____ K Ω // _____ pF
8. Operating temperature range : _____ to _____ $^{\circ}$ C
9. Package type : _____

DIMENSIONS

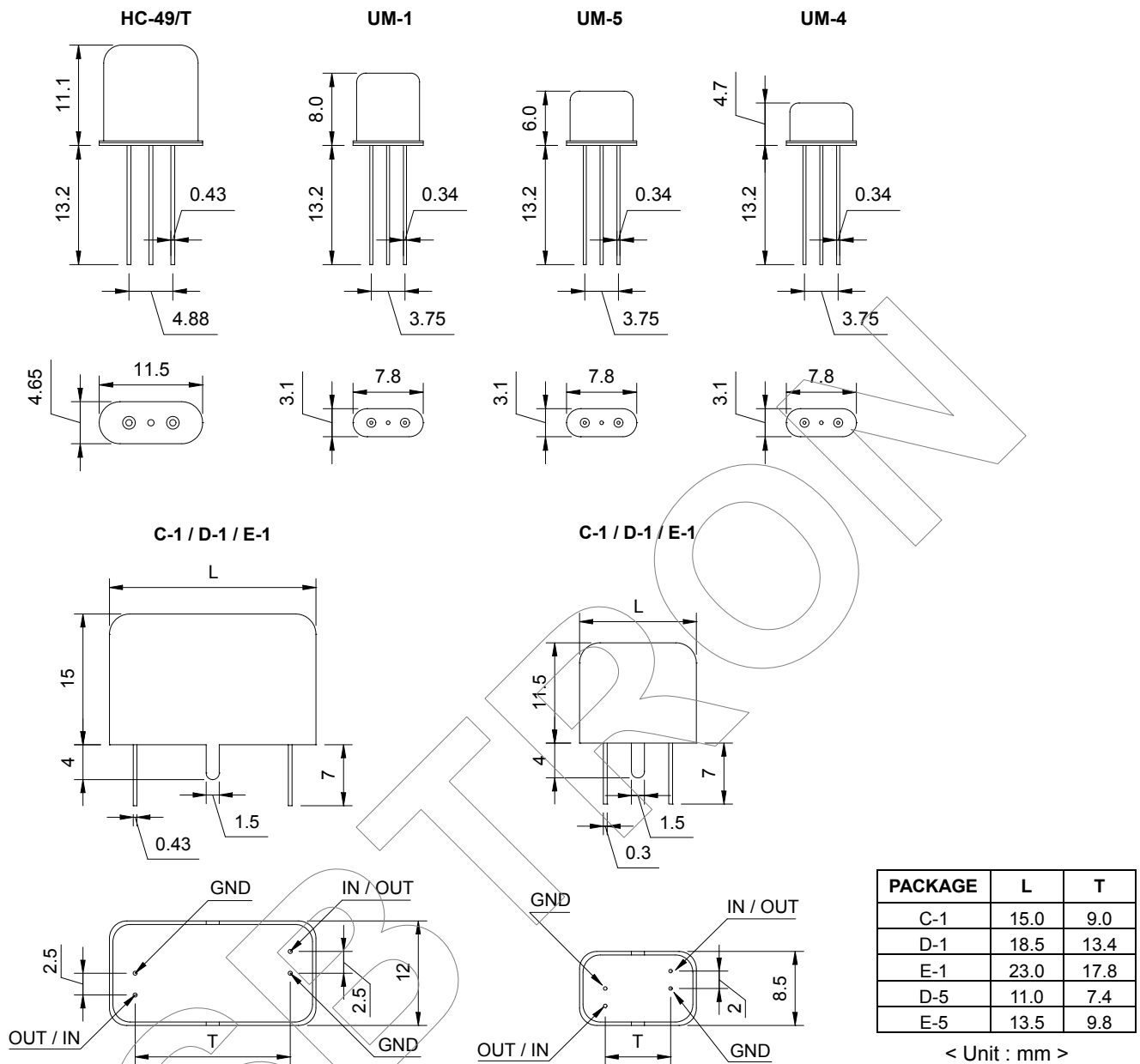

ENVIROMENTAL AND MECHANICAL SPECIFICATIONS

Shock test	Random drop on hard wooden board 3 times from a height of 50cm. The electrical data follows the requirement.
Vibration test	Frequency with amplitude of 1.5mm sweeping between 10Hz to 55 Hz within about 1 minute for 2 ours minimum on each direction. The electrical data follows the requirement.
Seal integrity	Bubble test in Perfluorocarbon at +125 °C ± 5 °C for 60 seconds minimum.
Solderability	The lead is immersed in a +230 °C ± 5 °C solder (Sn63%) bath within 2 ± 0.5 seconds. The dipping surface of the lead shall be at least 95% covered with a continuous new solder coating.
Invariable humidity	Stored at +40 °C ± 3 °C and RH 93% ± 2% for 48 hours and then at normal condition for 2 hours before testing without distinct damage. To the surface.

GLOSSARY

PARAMETER	DEFINITION
Nominal frequency (MHz)	Specified center frequency (f_0).
Pass band width (KHz)	The frequency band width in which the attenuation is equal to a specified value A.
Stop band width (KHz)	The frequency band width in which the attenuation is equal to a specified value B.
Insertion loss (dB)	Power loss from the presence of the filters in a circuit. It is referenced of the minimum attenuation point within the pass band.
Ripple (dB)	Within a pass band, the difference between maximum and minimum attenuation.
Spurious (dB)	Minimum attenuation caused by unusual response.
Guaranteed attenuation (dB)	The minimum attenuation guaranteed at stop band.
Terminating impedance ($K\Omega/pF$)	A signal impedance and a load impedance of a filter.

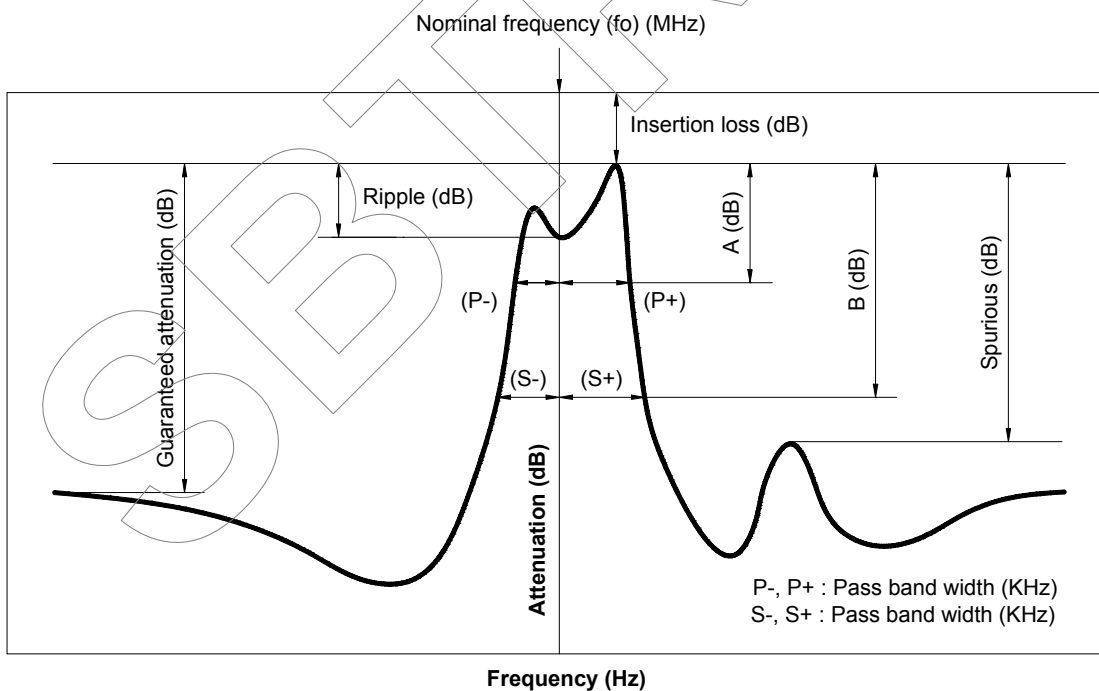

TEST CIRCUIT

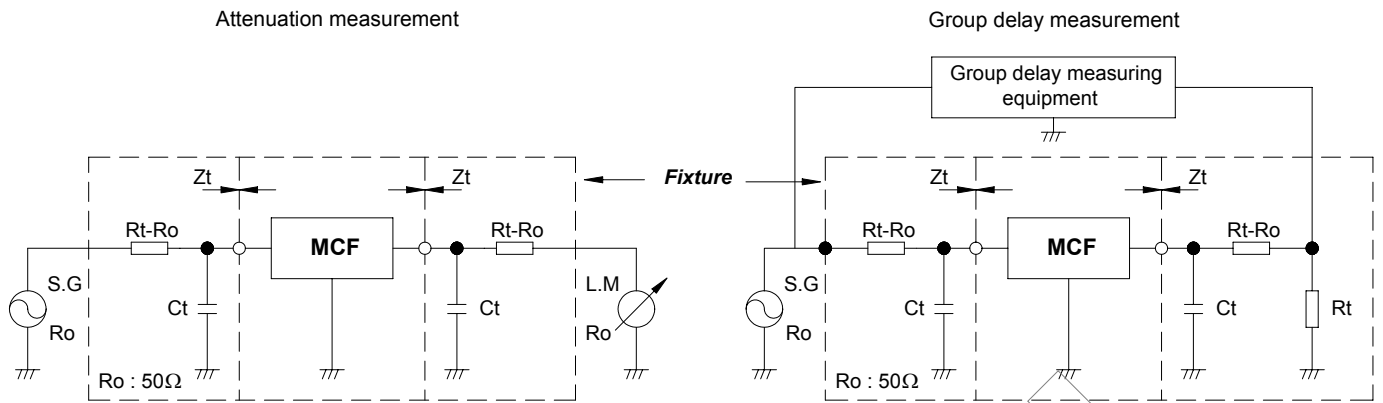

MEASURING CIRCUIT OF INTERMODULATION

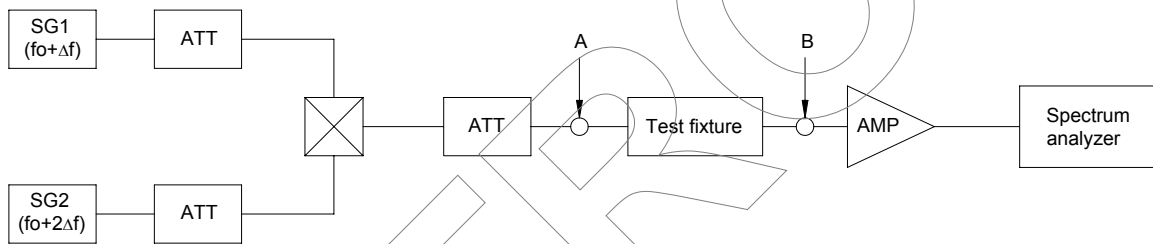

MEASURING OF INTERMODULATION

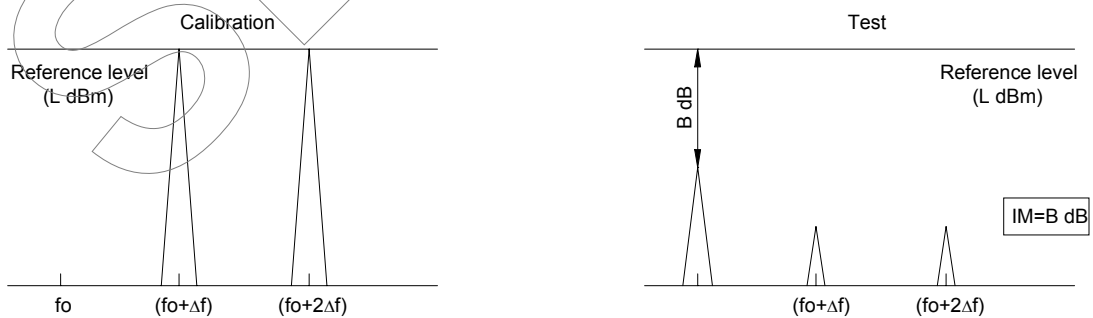

$IM=B$ (dB) at input level of point A (pin)
 $ip=pin+1/2B$ (dBm) (where, ip=intercept point)