

GPS-Disciplined Rubidium Clock

AR51A-07

Industrial/ Military Compact Low Profile

Key Features

- ❖ GPS disciplined Rubidium clock
- ❖ SAASM Code Time and Frequency Receiver (option)
- ❖ Outputs: 10MHz, 1PPS (TTL & RS-422), TOD (Have Quick)
- ❖ Input: GPS antenna, 1PPS, TOD (Have Quick)
- ❖ Frequency Accuracy : $2E-12$
- ❖ 1PPS Accuracy: Typ. 20ns (RMS)
- ❖ Holdover (without disciplining): Typ. $1\mu\text{s}/24$ hours, $5E-11/\text{month}$
- ❖ Operating Temperature:(-40°C opt.) -25°C to $+65^{\circ}\text{C}$ (71°C Emergency)
- ❖ Control and monitoring : RS-232 (input & output), RS-422 (output), MIL-STD-1553 (option)
- ❖ Graphic User Interface (GUI) Software for PC
- ❖ Supply Voltage: 22-32 VDC per MIL-STD-704D
- ❖ External battery input for power back-up
- ❖ Network Time Server: NTP. Time Accuracy $< 300\mu\text{s}$ (option))



Low Profile!

- ❖ Full MIL-STD qualification for military Airborne Applications
- ❖ Vibration isolator (option)

Description

The **AR51A-07** unit is an industrial/military low profile GPS-Disciplined Rubidium Clock which offers an excellent stability and accuracy. The unit includes a Rubidium-Atomic-Standard which is phase-locked to the GPS or other external inputs. All outputs are derived from the Rubidium-Atomic-Standard maintains this standard accurate time and frequency even when GPS reception is interrupted. The unit offer time accuracy of $< 20\text{ns}$ RMS and Frequency accuracy better than $2E-12$.

The AR51A-07 offers (option) the latest Selective Availability Anti-Spoofing (SAASM) technology. It therefore provides the latest GPS security against jamming and spoofing. Receiver operation modes are standalone, differential or common-view.

The unit has Have Quick (ICD-GPS-060) input and output which is essential for secure radio communication applications. The unit also has the ability to be remote controlled via MIL-STD-1553RT channel which is required in airborne applications.

The AR51A-07 is designed for demanding platforms such as airborne, helicopters, UAV's, shipboard and ground mobile.

Applications

- ❖ Secure Communication
- ❖ ELINT Receivers
- ❖ Electronic warfare
- ❖ Network Synchronization
- ❖ Radar, Bi-static Radar
- ❖ Field calibration
- ❖ Telemetry test fields
- ❖ C4I (Command, Control, Communications, Computer & Intelligence)
- ❖ Range Timing
- ❖ Satellite Communication Stations

SPECIFICATIONS

All specs are at room temperature, quiescent conditions, sea level ambient unless otherwise specified.

Input & Outputs

Outputs	1 x 10MHz, Sine wave (8±3) dBm SMA / 50Ω 2 X 1PPS TTL/50Ω 5 x 1PPS ICD-GPS-060/ 50Ω 4 x 1PPS RS-422 RAW 1PPS TTL/50Ω (Auxiliary output) 5 X TOD ICD-GPS-060 / 100KΩ	
Input	TOD ICD-GPS-060 TTL/100K Ω GPS Antenna External 1 PPS ICD-GPS-060/ 50Ω Encrypted military GPS keys (KYK-13/KOI-18)	
Communication	RS232 (CLI) (input/output) for control and monitoring: setting time/date, delay correction for 1PPS 10ns steps, mode of operation; disciplining to GPS/Ext 1PPS, holdover, UTC time, GPS Time, Local Time, Day Light Saving etc....(see CLI document for more information). Baud rate: 19,200, Control: 1, N, 8 CLI (RS422), derived from RS232 output. For monitoring purpose only. LAN – NTP / MIL- STD-1553RT (MUX-BUS) optional GUI for PC is available :Time, Date, Position, Status, BIT (Built in test) etc.	

Performance

Time (1PPS)	Long- term Accuracy	Disciplined to GPS or to an External synchronization source	50ns RMS (typ. 20ns RMS) @ 25°C, relative to an external ref.
		Time Drift without GPS (Hold-Over)	< 1µs/24hr (Typ.)
Frequency (10MHz)	Long Term Stability	Disciplined to GPS or to Ext. 1PPS	< 2E-12 (24 hour average, const temp.)
		Free running Rubidium-Standard	5E-11 / month drift in holdover
	Short Term Stability	< 4E-11 @ 1s	
	Temperature Stability	±3E-10 over -25°C to +65°C (-40°C opt.)	
	Phase Noise (Typ.)	≤ -94dBc/Hz @ 1Hz ≤-124dBc/Hz @ 10Hz ≤-144dBc/Hz @ 100Hz ≤-147dBc/Hz @ 1KHz ≤-147dBc/Hz @ 10KHz	
	Harmonics	-45 dBc	
	Spurious	<-75 dBc @ ± 100KHz from carrier	
	Warm-up	Rb Lock < 4 min 5E-10 within < 7 min 5E-11 within < 60 min, 1E-11 within < 4hrs 2E-12 within < 24 hrs.	
Retrace	± 4E-11		

SPECIFICATIONS *(continue)*

All specs are at room temperature, quiescent conditions, sea level ambient unless otherwise specified.

Power Supply

Input Voltage	22-32 VDC (28 VDC Typ.) per MIL-STD-704D
Power	< 26 Watt @ 28 VDC (warm-up) < 14 Watt @ 28 VDC @ 25°C (steady-state)
Battery Back-Up	External power input for battery back-up via the main power inlet Automatically operated when the main power reduces to 24 VDC

Industrial GPS Receiver

Tracking	L1 frequency (1575 MHz), C/A code 12 parallel tracking channels
Position	Lat., long., alt.
Position Accuracy	6m CEP (50%) w/o SA
GPS Antenna DC Voltage	5V
Acquisition Time	Warm start 45 second, Cold start < 50 second (worst case)

SAASM GPS Receiver *(option)*

Tracking	L1/L2 frequencies, C/A & P(Y) codes, 12 parallel tracking channels
Position	Lat., long., alt.
Position Accuracy	2m CEP (SDGPS)
GPS Antenna DC Voltage	5V
Acquisition Time	Warm/Cold start < 13 min (worst case)

Dimensions & Weight

Dimensions	245 mm (w) x 166 mm (h) x 56 mm (d)
weight	1.5 Kg

Environmental

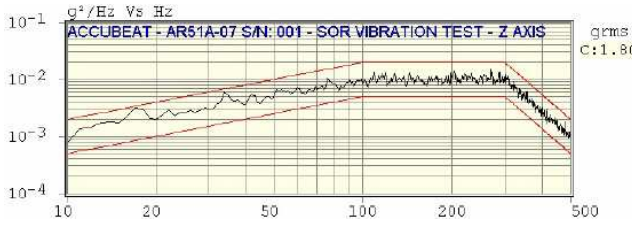
Temperature	Operating: -25°C to +65°C (-40°C to +65°C Opt.) Emergency: +71°C for 60 minutes Storage: -40°C to +71°C																														
Temperature Altitude	-40°C to +65°C (+71°C for 60 minutes) 0 to 60,000 f t																														
Humidity	95% non condensing																														
Random Vibration	2.45gRMS as per the following profile: <div style="display: flex; align-items: center;">  <table border="1" style="margin-left: 20px; border-collapse: collapse; text-align: center;"> <thead> <tr> <th colspan="3">GRMS</th> </tr> <tr> <th>TOTAL</th> <th colspan="2">RANDOM</th> </tr> <tr> <th>Con</th> <th>Ref</th> <th>Con</th> </tr> </thead> <tbody> <tr> <td style="background-color: yellow;">2.45</td> <td style="background-color: yellow;">1.79</td> <td style="background-color: yellow;">1.80</td> </tr> <tr> <th colspan="3">TONES</th> </tr> <tr> <th>Freq</th> <th>Ref</th> <th>Con</th> </tr> <tr> <td style="background-color: yellow;">4.30</td> <td style="background-color: yellow;">0.11</td> <td style="background-color: yellow;">0.11</td> </tr> <tr> <td style="background-color: yellow;">17.20</td> <td style="background-color: yellow;">1.21</td> <td style="background-color: yellow;">1.23</td> </tr> <tr> <td style="background-color: yellow;">34.40</td> <td style="background-color: yellow;">1.75</td> <td style="background-color: yellow;">1.77</td> </tr> <tr> <td style="background-color: yellow;">51.60</td> <td style="background-color: yellow;">1.05</td> <td style="background-color: yellow;">1.03</td> </tr> </tbody> </table> </div>	GRMS			TOTAL	RANDOM		Con	Ref	Con	2.45	1.79	1.80	TONES			Freq	Ref	Con	4.30	0.11	0.11	17.20	1.21	1.23	34.40	1.75	1.77	51.60	1.05	1.03
GRMS																															
TOTAL	RANDOM																														
Con	Ref	Con																													
2.45	1.79	1.80																													
TONES																															
Freq	Ref	Con																													
4.30	0.11	0.11																													
17.20	1.21	1.23																													
34.40	1.75	1.77																													
51.60	1.05	1.03																													
Mechanical Shock - Operation	MIL-STD-810C/E, Method 516.2, Proc. 1 (15g / Half sine/ 3 axis/ 6 shocks per axis)																														
Mechanical Shock - crash	X-40G, Y-15G, Z-20G, 11ms, Half Sine, Total 12 shocks																														
Bench Handling Shock	MIL-STD-810C/E, Method 516.2, Procedure V																														
Rain	MIL-STD-810E Method 506.3 procedure I																														
Dust	MIL-STD-810E Method 510.3																														
Salt Atmosphere	MIL-STD-810E, Method 509.3, Procedure I																														
Bonding	≤2.5 mΩ																														
EMI / RFI	MIL-STD-461B/C Part: 5 (CE01, CE03, CE07, RE02, CS01, CS02, CS06, RS02, RS03)																														

Reliability, Maintainability, Testability

MTBF	> 20,000 hours @ 30°C, ARW, MIL-HBK-217F
MTTR – O Level	12 min. to replace failed unit (including warm-up time)
MTTR – I Level	34 min. to replace failed module (including warm-up time)
BIT (Built In Test)	On-line BIT – Automatic, Covers 90% of all failures

SPECIFICATIONS *(continue)*

All specs are at room temperature, quiescent conditions, sea level ambient unless otherwise specified.

Principles of Operation

The following block diagrams depict the operation of the AR51A-07. The unit includes Rubidium Standard and accepts Input from either internal GPS receiver, external 1PPS or external TOD (H.Q). All outputs are derived from the internal Rubidium Clock, which is phase locked by a digital PLL to the selected input. Thus, the Rubidium Clock - frequency and time - follows the GPS on average. If GPS reception is lost for short or long periods of time the Rubidium Clock continues to maintain accurate time and frequency without phase interruption.

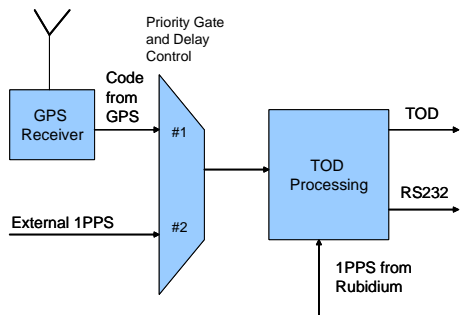

Data flow & Inputs Selection

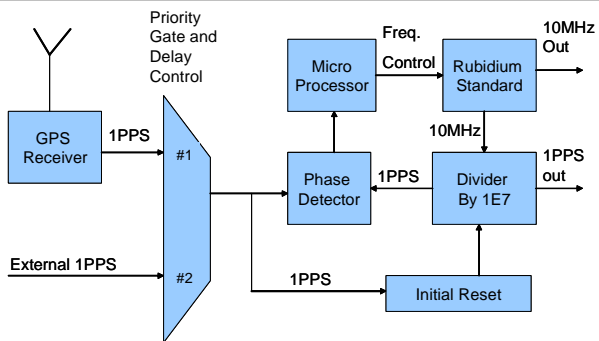

Rubidium-GPS D-PLL and Inputs

Typical Performance Plots

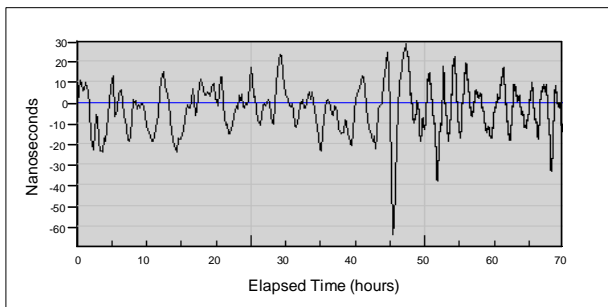

Typical time error fluctuations when disciplined to GPS

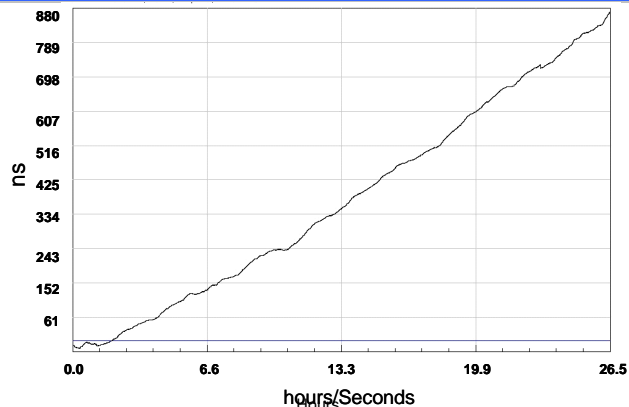

Typical time error in Holdover (without GPS)

Graphic User Interface (GUI) Software for PC (Opt.)

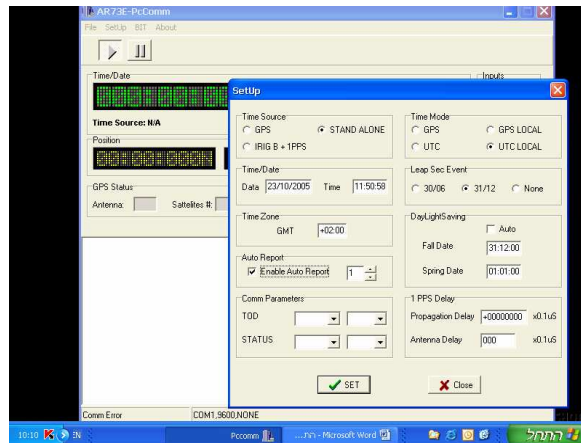
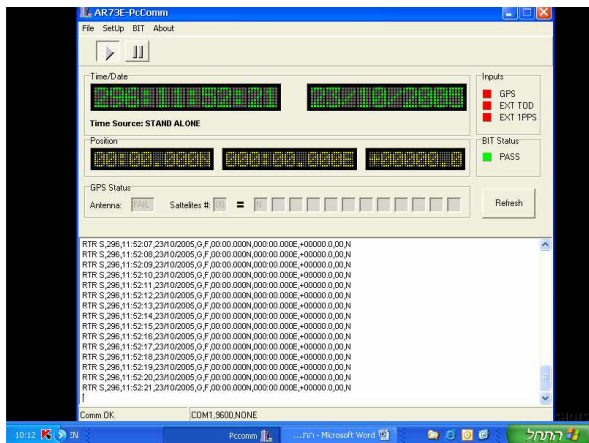

SPECIFICATIONS *(continue)*

All specs are at room temperature, quiescent conditions, sea level ambient unless otherwise specified

Mechanical ICD

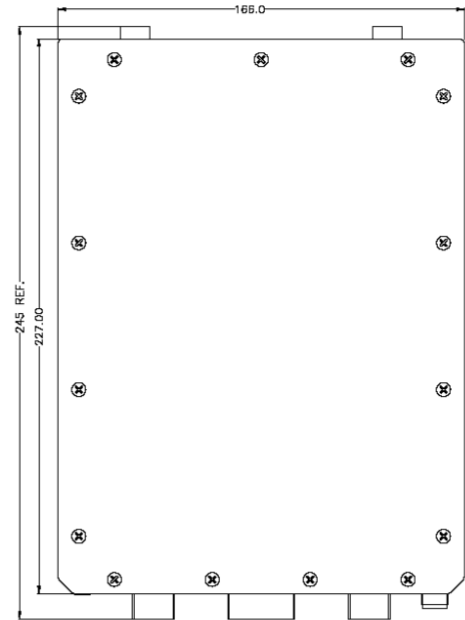
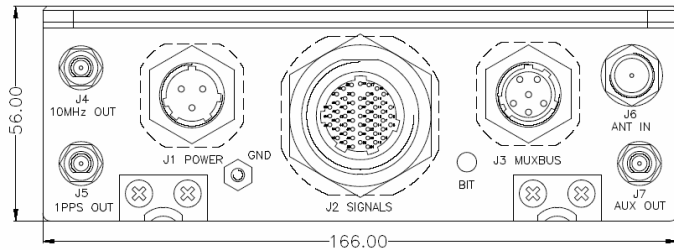
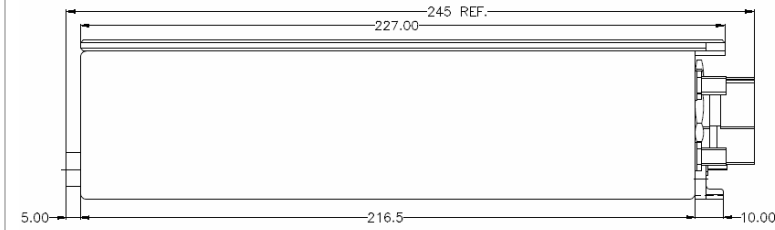

Electrical ICD

Connector		I/O
J1 - Supply		OUT
J2 - Signals	TOD TTL/100K ohm x 5	OUT
	1 PPS PTTI x 5	OUT
	1 PPS RS-422 x 4	OUT
	1 PPS TTL/50 ohm x 1	OUT
	Aux RS-422 x 1	IN/OUT
	CLI RS-232 x 1	IN/OUT
	1PPS ICD-GPS-060 x 1	IN
	TOD TTL/100K ohm x 1	IN
	MUX-Bus Address	IN
	Overall BIT	OUT
J3 - MUXBUS	MIL-STD-1553RT, Female	IN/OUT
J4 - 10MHz OUT	Sine-wave, 8 ±3dBm, 50Ω, SMA, Female	OUT
J5 - 1PPS OUT	TTL/50 ohm, SMA, Female	OUT
J6 - ANT IN	L1/L2, TNC, 50Ω, Female	IN
J7 - AUX OUT	1PPS TTL/50 ohm (RAW), SMA, Female,	OUT

HOW TO ORDER

OPTIONS		AccuBeat P/N	Note
Number	Description		
01	Military GPS	AR51007-01	
02	Standard unit, commercial GPS	AR51007-02	
04	Improved ADEV and Phase Noise	AR51007-04	
05	NTP/ LAN, 2PPS, Ext. 1PPS TTL	AR51007-05	
06	NTP/LAN	AR51007-06	